

Torque Sensor

Mini-Smart Torque Sensor

Type 4502A...

Type 4502A... torque sensors operate on the strain gage principle and supply an analog output signal of $\pm 0 \dots 5$ V which is contactless transferred. Available also with integrated rotational angle/speed measurement.

- Smart (integral measuring electronics)
- Interference resistance due to active torque output (± 5 VDC), electrically isolated from supply and measuring signal
- Non-contact signal transfer
- Unipolar supply
- Highly responsive to dynamic peaks
- Maintenance-free
- Standardized mechanical connections:
 - 1/4" hex socket DIN3126
 - Square socket (size depending on measuring range)
 - Cylindrical shaft ends
- Extremely compact
- Suitable for pulse tool operation
- Optional rotational angle measurement

Description

The Mini-Smart torque sensor uses strain gage technology. The torque signal is transmitted from the rotating shaft via frequency modulation and is processed as an analog signal.

The rotational angle signal with two tracks of each 360 pulses per revolution and track is available as TTL-signal. An external electrical control input is standard.

Application

The Mini-Smart torque sensor with rotating measuring shaft is suitable both for dynamical detection of starting torque and breakway torque for bolting and assembly techniques and for quality assurance in production and laboratory.

Due to its standardized connections the device can be quickly adapted to air, electronic and pulse tools.



Version Q



Version H



Version R

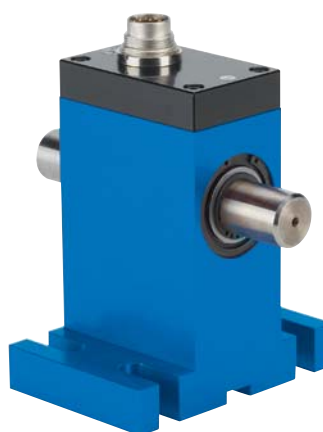

Version RAU



Technical Data

Mechanical Basic Data

Measuring range	N·m	±0,5 ... 1 000
Rated torque M_{nom}	N·m	0,5 ... 1 000
Overload capacity		
Service torque		1,5 x M_{nom}
Limiting torque		1,5 x M_{nom}
Rotational angle/- speed measur. (Version QA, HA, RA, RAU)	pulses/ revolut.	2x360, 90 ° displaced, TTL
Nominal speed		
≤18 N·m	1/min	12 000
20 ... 160 N·m	1/min	9 000
250 ... 1 000 N·m	1/min	7 000
Version QA, HA, RA, RAU (rotational angle measurement)	1/min	7 000
Housing material		Anodized aluminum
Protection class		IP40

General Electrical Specifications

Cut-off frequency -3 dB	kHz	3
Accuracy class		0,2

Linearity error including hysteresis	% FSO	<±0,2
Output signal	VDC	±0 ... 5
at rated torque (rated value)	VDC	5
Load resistance	kΩ	>10
Temp. influence on the zero point	% FSO/°C	<±0,015
Temp. influence on the nominal value	% FSO/°C	<±0,015
Control signal	%	100 ±0,2
100 % control input	VDC	"On" 5 ... 30 "Off" 0 ... 2
Operating temperature range (Rated temperature range)	°C	10 ... 60
Service temperature range	°C	0 ... 70
Storage temperature range	°C	-25 ... 80
Electrical connection		12 pin built-in connector
Supply voltage	VDC	11 ... 26
Power consumption	W	<1

Dimensions



Torque sensor with standard square socket connection

Version Q

- With rotating shaft
- Drive - square socket
- Output - square drive

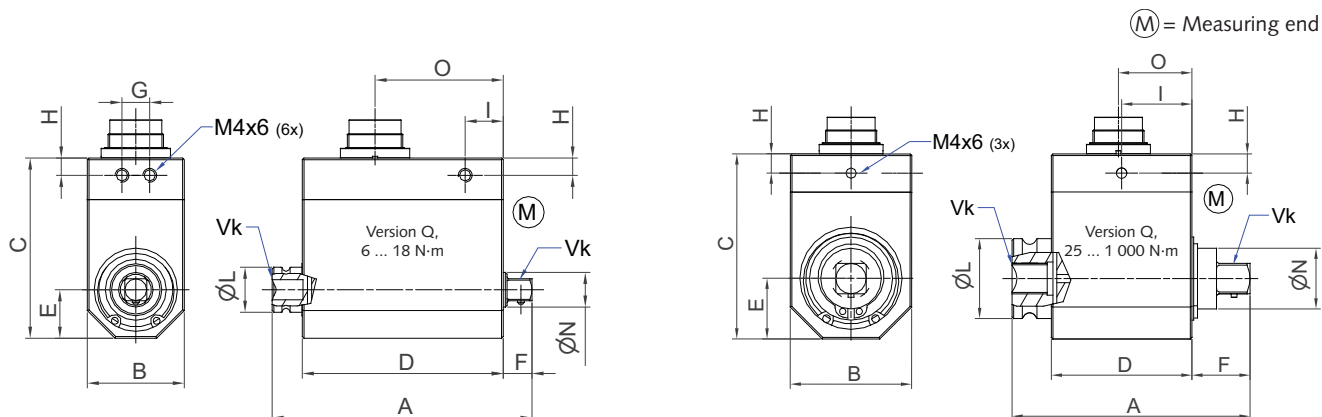

Table Version Q

Threads for mounting: M4, 6 mm depth

Type	Measuring range N·m	Square size	A	B	C	D	E	F	G	H	I	øL	øN	O	Axial force N max.	Radial force N max.
4502A012Q	12	1/4"	75	28	52	58	14	8,5	8	5	11	13	10	37	150	30
4502A018Q	18	1/4"	75	28	52	58	14	8,5	8	5	11	13	10	37	150	30
4502A050Q	50	3/8"	74,5	38	58	44	19	18	*	6	22	25	19	23	500	60
4502A063Q	63	3/8"	74,5	38	58	44	19	18	*	6	22	25	19	23	500	60
4502A100Q	100	1/2"	79	38	58	44	19	22,5	*	6	22	25	19	23	700	100
4502A150Q	150	1/2"	79	38	58	44	19	22,5	*	6	22	25	19	23	1 000	100
4502A160Q	160	1/2"	79	38	58	44	19	22,5	*	6	22	25	19	23	1 000	100
4502A250Q	250	3/4"	97	58	76	50	29	30	*	5	25	40	30	27	2 000	150
4502A300Q	300	3/4"	97	58	76	50	29	30	*	5	25	40	30	27	2 000	150
4502A500Q	500	3/4"	97	58	76	50	29	30	*	5	25	40	30	27	2 000	150
4502A1k0Q	1 000	1"	112	73	90	57	36,5	34,5	*	5	28,5	50	40	28,5	4 000	250

Type	Torsional rigidity N·m/rad	Angle of twist M_{nom} °	Inertia kgcm ²		Weight kg
			Measuring end	Drive end	
4502A012Q	1 200	0,55	0,0121	0,0157	0,19
4502A018Q	1 200	0,85	0,0121	0,0157	0,19
4502A050Q	9 000	0,32	0,043	0,0843	0,28
4502A063Q	9 000	0,4	0,043	0,0843	0,28
4502A100Q	14 100	0,48	0,051	0,086	0,3
4502A150Q	14 100	0,61	0,051	0,086	0,3
4502A160Q	14 100	0,65	0,051	0,086	0,3
4502A250Q	71 650	0,21	0,465	0,758	0,92
4502A300Q	71 650	0,25	0,465	0,758	0,92
4502A500Q	71 650	0,4	0,465	0,758	0,92
4502A1k0Q	184 500	0,31	1,38	2,05	1,57

Dimensions



Torque sensor with standard square socket connection

Version QA

- With rotating shaft
- Drive - inside square socket
- Output - external square drive
- Rotational angle measurement

(M) = Measuring end

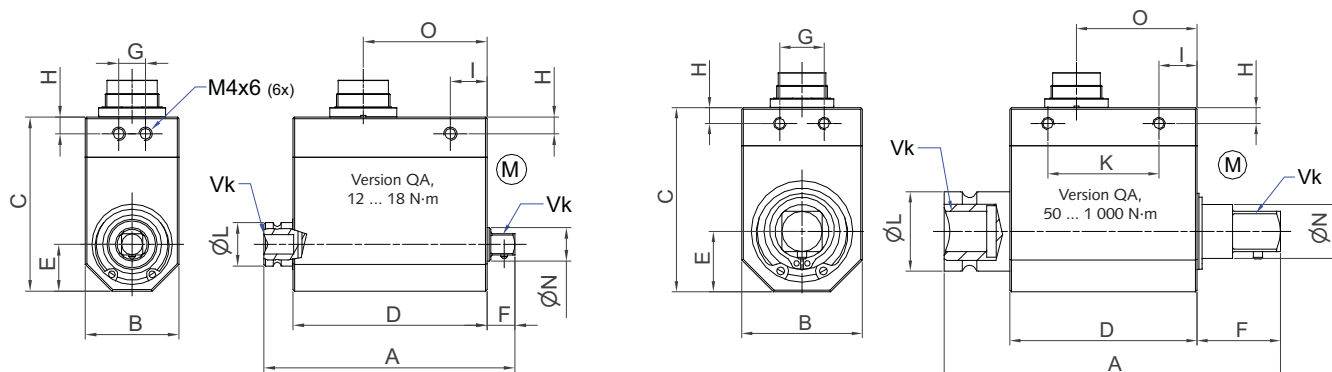

Table Version QA (with rotational angle measurement)

Threads for mounting: M4, 6 mm depth

Type	Measuring range N·m	Square size Vk	A	B	C	D	E	F	G	H	I	K	øL	øN	O	Axial force N max.	Radial force N max.
4502A012QA	12	1/4"	75	28	52	58	14	8,5	8	5	11	-	13	10	37	150	30
4502A018QA	18	1/4"	75	28	52	58	14	8,5	8	5	11	-	13	10	37	150	30
4502A050QA	50	3/8"	101	38	58	59	19	21,5	14	5	12	35	25	17	38	500	60
4502A063QA	63	3/8"	101	38	58	59	19	21,5	14	5	12	35	25	17	38	500	60
4502A100QA	100	1/2"	106	38	58	59	19	26,5	14	5	12	35	25	17	38	700	100
4502A150QA	150	1/2"	106	38	58	59	19	26,5	14	5	12	35	25	17	38	1 000	100
4502A160QA	160	1/2"	106	38	58	59	19	26,5	14	5	12	35	25	17	38	1 000	100
4502A250QA	250	3/4"	135	58	76	64	29	40	30	5	14	36	40	30	40	2 000	150
4502A300QA	300	3/4"	135	58	76	64	29	40	30	5	14	36	40	30	40	2 000	150
4502A500QA	500	3/4"	135	58	76	64	29	40	30	5	14	36	40	30	40	2 000	150
4502A1k0QA	1 000	1"	177	73	90	73	36,5	57,5	45	5	14	45	50	40	44	4 000	250

Type	Torsional rigidity N·m/rad	Angle of twist M_{nom}°	Inertia kgcm ²		Weight kg
			Measuring end	Drive end	
4502A012QA	1 200	0,55	0,013	0,0157	0,2
4502A018QA	1 200	0,85	0,013	0,0157	0,2
4502A050QA	6 100	0,47	0,055	0,11	0,41
4502A063QA	6 100	0,59	0,055	0,11	0,41
4502A100QA	10 100	0,6	0,069	0,1	0,42
4502A150QA	10 100	0,85	0,069	0,1	0,42
4502A160QA	10 100	0,9	0,069	0,1	0,42
4502A250QA	63 600	0,23	0,68	1,0	1,24
4502A300QA	63 600	0,27	0,68	1,0	1,24
4502A500QA	63 600	0,45	0,68	1,0	1,24
4502A1k0QA	127 000	0,45	2,45	3,25	2,48

Dimensions



Torque sensor with standard 1/4" hex
DIN3126 form E/F, **Version H or HA**

- With rotating shaft
- Drive - hex shaft
- Output - hex socket
- Rotational angle measurement (Version HA)
- Quick action chuck

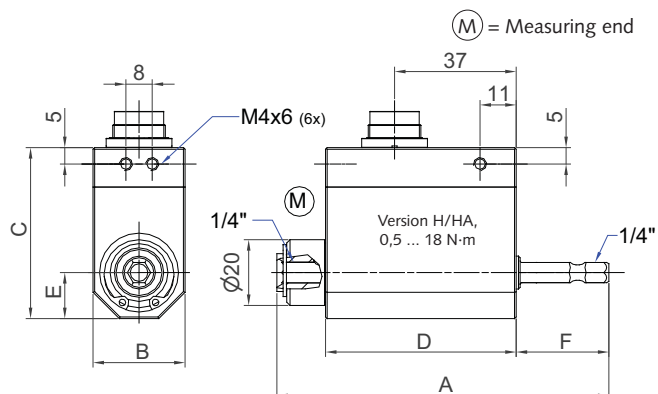

Table Version H or HA (with rotational angle measurement)

Threads for mounting: 6x M4, 6 mm depth

Type	Measuring range N·m	A	B	C	D	E	F	Axial force N max.	Radial force N max.
4502A0,5H, ...HA	0,5	101	28	52	58	14	28	20	5
4502A001H, ...HA	1	101	28	52	58	14	28	50	10
4502A002H, ...HA	2	101	28	52	58	14	28	50	20
4502A006H, ...HA	6	101	28	52	58	14	28	150	40
4502A012H, ...HA	12	101	28	52	58	14	28	150	40
4502A018H, ...HA	18	101	28	52	58	14	28	200	40

Type	Torsional rigidity Nm/rad	Angle of twist M_{nom}°	Inertia $kgcm^2$		Weight kg
			Measuring end	Drive end	
4502A0,5H, ...HA	180	0,16	0,0134	0,0193	0,2
4502A001H, ...HA	180	0,32	0,0134	0,0193	0,2
4502A002H, ...HA	260	0,44	0,0135	0,0194	0,2
4502A006H, ...HA	505	0,68	0,0137	0,0216	0,21
4502A012H, ...HA	690	1,0	0,0140	0,0248	0,21
4502A018H, ...HA	690	1,5	0,0140	0,0248	0,21

Dimensions



Torque sensor 1 ... 50 N·m with shaft end,

Version R or RA

- With rotating shaft
- Rotational angle measurement (Version RA)

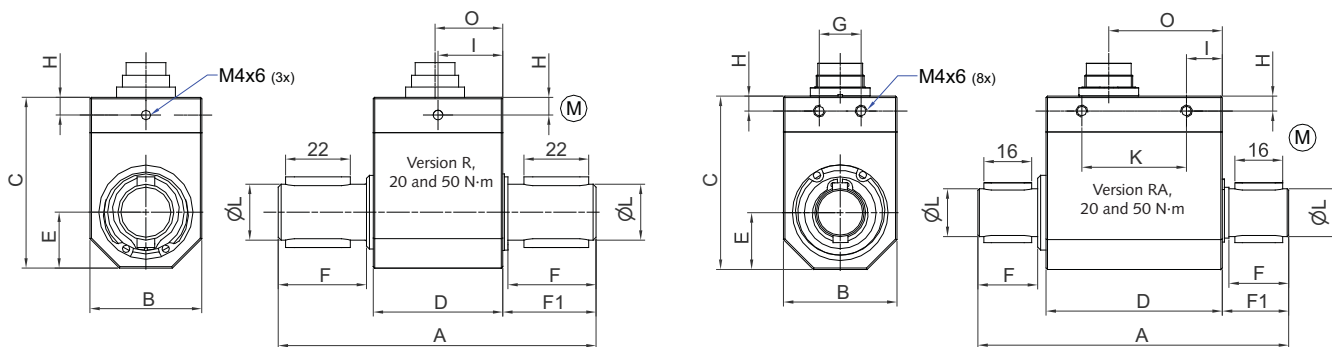
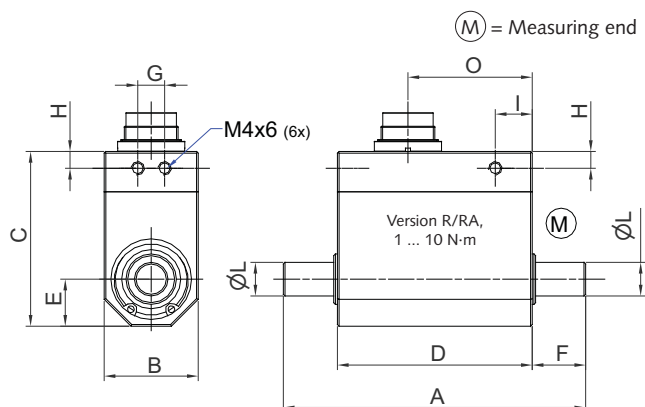

Table Version R or RA (with rotational angle measurement)

Threads for mounting: M4, 6 mm depth

Type	Meas. range N·m	A	B	C	øL g6	F	F1	D	E	H	I	K	G	N	O	Axial force N max.	Radial force N max.
4502A001R, ...RA	1	90	28	52	10	15,9	17	58	14	5	11	-	8	shaft	37	20	5
4502A002R, ...RA	2	90	28	52	10	15,9	17	58	14	5	11	-	8	shaft	37	50	5
4502A005R, ...RA	5	90	28	52	10	15,9	17	58	14	5	11	-	8	shaft	37	50	10
4502A010R, ...RA	10	90	28	52	10	15,9	17	58	14	5	11	-	8	shaft	37	150	20
4502A020R	20	108	38	58	19	30	31,7	44	19	6	22	-	-	K**	23	150	50
4502A050R	50	108	38	58	19	30	31,7	44	19	6	22	-	-	K**	23	150	100
4502A020RA	20	104	38	58	16	20	23	59	19	5	12	35	14	K**	38	150	50
4502A050RA	50	104	38	58	16	20	23	59	19	5	12	35	14	K**	38	150	50

**With feather keyways (2x180 °) according to DIN6885

Type	Torsional rigidity N·m/rad	Angle of twist M_{nom}°	Inertia kgcm ²		Weight kg
			Measuring end	Drive end	
4502A001R, ...RA	317	0,17	0,0146	0,0147	0,15
4502A002R, ...RA	317	0,36	0,0146	0,0147	0,15
4502A005R, ...RA	855	0,34	0,015	0,015	0,16
4502A010R, ...RA	855	0,67	0,015	0,015	0,16
4502A020R	5 450	0,21	0,061	0,073	0,33
4502A050R	9 500	0,3	0,062	0,075	0,33
4502A020RA	5 450	0,21	0,9	1,02	0,4
4502A050RA	8 190	0,35	0,91	1,04	0,4

Dimensions



Torque sensor 100 ... 1 000 N·m with shaft end and separate mounting base, **Version RA**

- With rotating shaft
- Rotational angle measurement
- Shaft ends each with two keyways in accordance with DIN 6885

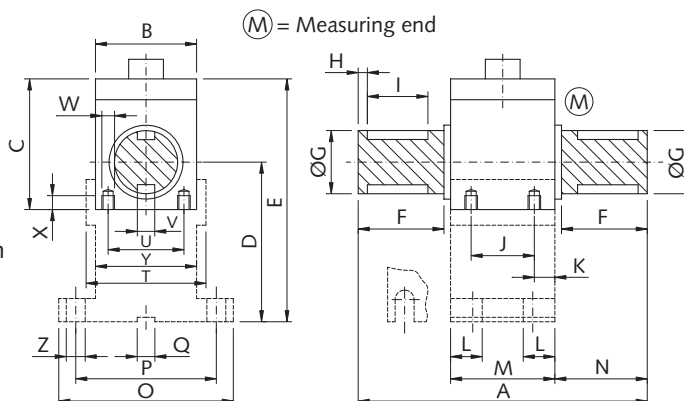

Table Version RA (with rotational angle measurement)

Type	Measuring range N·m	A	B	C	D	E	F	øG g6	H	I	J	K	L	M	N	O	P
4502A100RA	100	125	58	76	112	159	27	28	2	22	39	12,5	20	64	30,5	120	100
4502A200RA	200	125	58	76	112	159	27	28	2	22	39	12,5	20	64	30,5	120	100
4502A500RA	500	197	73	90	112	165,5	58	42	3	50	37	18	25	73	62	120	100
4502A1k0RA	1 000	197	73	90	112	165,5	58	42	3	50	37	18	25	73	62	120	100

Option mounting base

Type	Measuring range N·m	Q P9	T	U	V P9	W	X	Y	Z	Axial force N max.	Radial force N max.
4502A100RA	100	10	68	43	8	M5 4x	8	–	10	300	200
4502A200RA	200	10	68	43	8	M5 4x	8	–	10	300	200
4502A500RA	500	10	83	52	14	M6 4x	10	73	10	300	300
4502A1k0RA	1 000	10	83	52	14	M6 4x	10	73	10	500	300

Type	Measuring range N·m	Torsional rigidity N·m/rad	Angle of twist M_{nom} °	Inertia kgcm ²		Weight kg	Weight mounting base kg
				Measuring end	Drive end		
4502A100RA	100	28 600	0,2	0,665	0,605	1,13	1,06
4502A200RA	200	45 845	0,25	0,68	0,62	1,13	1,06
4502A500RA	500	130 000	0,22	3,2	2,63	2,84	1,23
4502A1k0RA	1 000	173 600	0,33	3,21	2,67	2,84	1,23

Dimensions



Torque sensor with shaft end and integral mounting base,

Version RAU

- This version can be used as functional check on tilt procedure or rotation monitoring
- Variable mounting positions, applications for left and right hand torque readings as well as the static and dynamic conditions are possible
- All RAU type sensors have an integrated rotational angle measurement

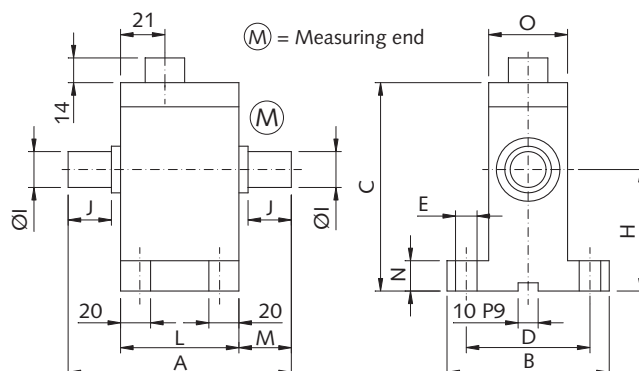

Table Version RAU (with rotational angle measurement)

Type	Measuring range N·m	A	B	C	D	E	H	øI g6	J	L	M	N	O	Size	Axial force N max.	Radial force N max.
4502A001RAU	1	90	58	83	45	7	45	10	15	58	16	12	28	1	20	10
4502A002RAU	2	90	58	83	45	7	45	10	15	58	16	12	28	1	50	10
4502A005RAU	5	90	58	83	45	7	45	10	15	58	16	12	28	1	100	20
4502A010RAU	10	90	58	83	45	7	45	10	15	58	16	12	28	1	100	30
4502A020RAU	20	106	85	102	60	9	63	17	22	59	23	15	38	2	150	100
4502A050RAU	50	106	85	102	60	9	63	17	22	59	23	15	38	2	150	100

Type	Measuring range N·m	Torsional rigidity N·m/rad	Angle of twist M_{nom} °	Inertia kgcm ²		Weight kg
				Measuring end	Drive end	
4502A001RAU	1	317	0,17	0,0146	0,0147	0,38
4502A002RAU	2	317	0,36	0,0146	0,0147	0,38
4502A005RAU	5	855	0,34	0,015	0,015	0,38
4502A010RAU	10	855	0,67	0,015	0,015	0,38
4502A020RAU	20	4 580	0,25	0,062	0,061	0,78
4502A050RAU	50	8 190	0,35	0,064	0,063	0,78

Electrical Connections

Pin Allocation of the 12 Pin Built-in Connector

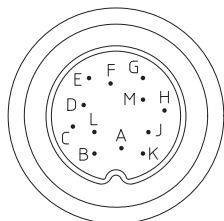

Function	PIN	Description
Supply	F	+U _B
	E	GND
Shield	M	In sensor connected to housing
Torque output	C	U _A ±5 VDC at M _{nom} at >2 kΩ 5 VDC at control signal activation R _{i,c} = 10 Ω, output short circuit proof relating to AGND
	D	AGND Ground relating to U _A
Angle of rotation sensor	H	+U _B 5 VDC
Supply	B	Track A Open collector output
Angle of rotation pulses	G	Track B Internal 1 kΩ resistance to 5 VDC (pull up), TTL-level As Track A, 90 ° displaced
100 % control input	K	Control Off: 0 ... 2 VDC On: 5 ... 30 VDC
	A	KGND Ground relating to control input
	J	Not connected

Included Accessories

- None

Optional Accessories	Type	Mat.-No.
Mounting base, for Version RA ranges 100 ... 200 N·m	KSM020014	18008587
Mounting base, for Version RA ranges 500 ... 1 000 N·m	KSM020015	18008588
Female connector with solder eye 12 pin	KSM000703	18008371
Connection cable, 5 m, 12 pin – open ends	KSM124970-5	18008943
Connection cable, 2,5 m, 12 pin – CoMo Torque	KSM185380-2,5	18008963

Please see data sheet 000-615 for cable connection.

Individual Application

The diverse model range guarantees user-friendly application such as tool calibration or in test stands – with or without mounting base.

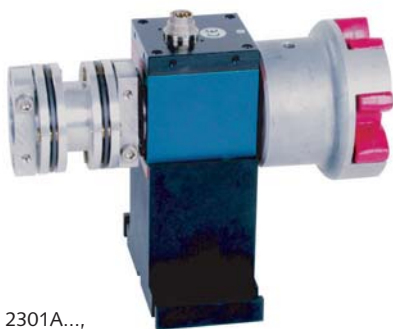

Couplings Type 2301A..., Type 2302A... or Type 2303A...

Application Example

Power tool control



Ordering Key

Type 4502A

Measuring Ranges in N·m/

Possible Versions

0,5	-	-	H	HA	-	-	-	0,5
1	-	-	H	HA	R	RA	RAU	001
2	-	-	H	HA	R	RA	RAU	002
5	-	-	-	-	R	RA	RAU	005
6	-	-	H	HA	-	-	-	006
10	-	-	-	-	R	RA	RAU	010
12	Q	QA	H	HA	-	-	-	012
18	Q	QA	H	HA	-	-	-	018
20	-	-	-	-	R	RA	RAU	020
50	Q	QA	-	-	R	RA	RAU	050
63	Q	QA	-	-	-	-	-	063
100	Q	QA	-	-	-	RA	-	100
150	Q	QA	-	-	-	-	-	150
160	Q	QA	-	-	-	-	-	160
200	-	-	-	-	-	RA	-	200
250	Q	QA	-	-	-	-	-	250
300	Q	QA	-	-	-	-	-	300
500	Q	QA	-	-	-	RA	-	500
1 000	Q	QA	-	-	-	RA	-	1k0

Versions

(Note Dependence with Measuring Range)

Square socket	Q
Square socket with rotational angle meas.	QA
1/4" hex socket	H
1/4" hex socket with rotational angle meas.	HA
Rotating shaft	R
Rotating shaft with rotational angle meas.	RA
Rotating shaft with rotational angle meas. and integral mounting base	RAU

Order Example:

Type 4502A018HA

Torque sensor: rated torque 18 N·m: **018**, Version **HA**: 1/4" hex socket with angle measurement