

Short description:

- Self aligning construction.
- Easy load cell access.
- Stainless Steel.
- Lift-off protection.
- Can be used with Load Cell models: AE-BM8.

Available models:

Model	Capacity	Full article description	
AE-BM-8-409	0,5t - 2t	AE-BM-8-409-0,5/2t	
	5t – 7,5t	AE-BM-8-409-5/7,5t	
	10t	AE-BM-8-409-10t	

Detailed specifications AE-BM-8-409:

Capacity:	0,5t - 2t	5t - 10t
Maximum vertical force (down)	15 kN	40 kN
Maximum vertical force (up)	10 kN	25 kN
Maximum horizontal force	5 kN	12 kN
Maximum horizontal movement	+2 / - 2 mm	+2 / - 2 mm

Specifications and dimensions are subject to change without notice and do not constitute any liability whatsoever.

Dimensions in mm:

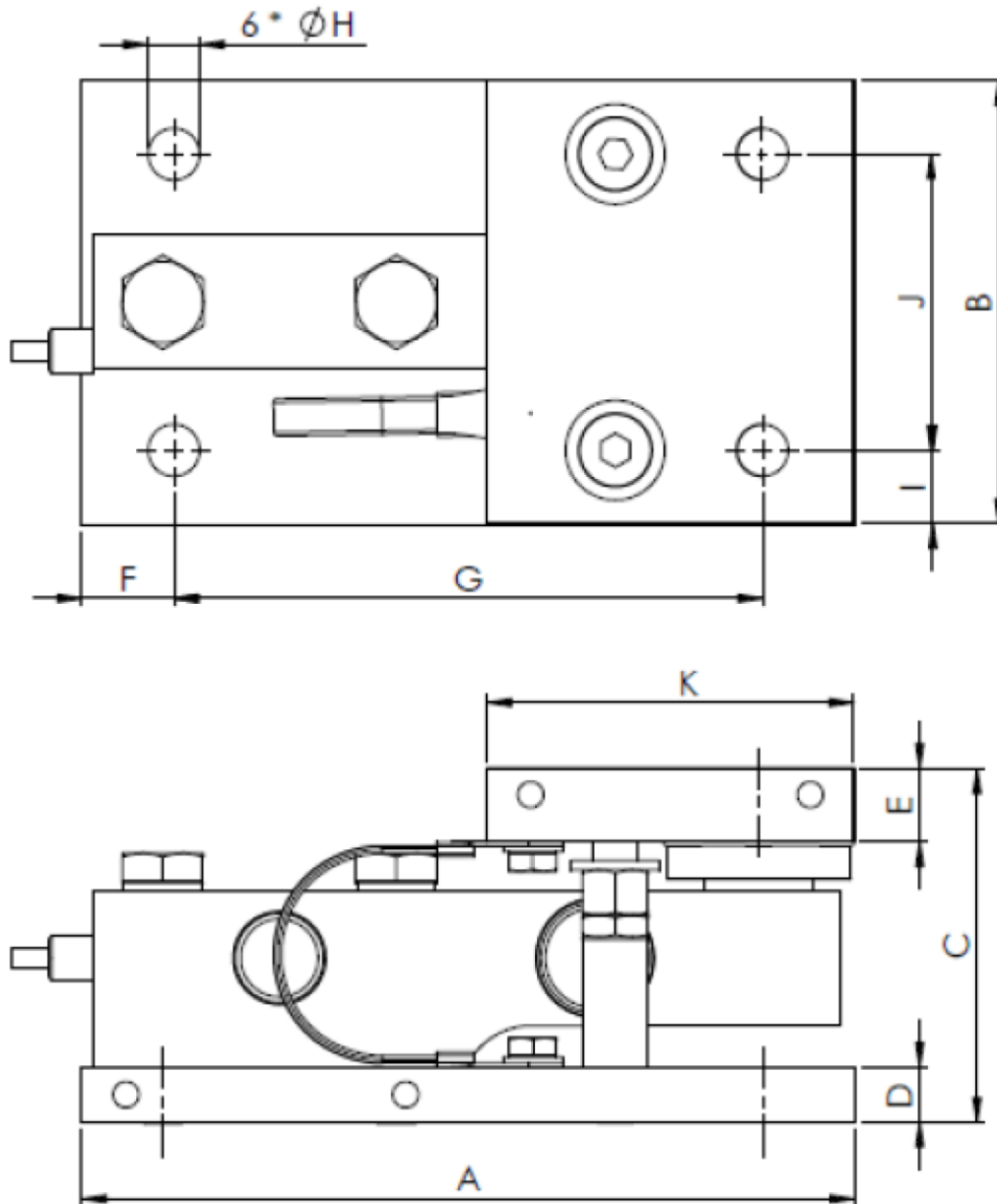

Dimension Capacity:	A	B	C	D	E	F	G	ØH	I	J	K
0,5t - 2t	210	120	96	15	20	25	160	14	20	80	100
5t – 7,5t	250	150	138	20	20	25	200	18	25	100	120
15t	260	150	153	20	30	25	210	18	25	100	130

Specifications and dimensions are subject to change without notice and do not constitute any liability whatsoever.