

PyroCouple, PyroEpsilon, PyroBus, PyroCAN

General Purpose Infrared Temperature Sensors



- Temperature ranges from -20°C to 1000°C (depending on model)
- Choice of precision optics for large or small targets at short or long distances
- Fast response with high stability
- Stainless steel housing, sealed to IP65
- Quick and easy installation
- Wide range of accessories

The Calnex Compact Series is a range of high quality, low cost non-contact sensors that measure the temperature of inaccessible or moving objects and materials. They measure temperatures from -20°C to 1000°C, accurately and consistently, with an outstanding response time of 240 ms. All models conform to industrial EMC standards.



PyroCouple with indicator

The **PyroCouple** is a simple infrared temperature sensor with a choice of analogue outputs. No complicated setup is required - just connect a temperature indicator and power supply, and instantly start taking measurements.

- Temperature ranges from -20°C to 500°C
- Suitable for non-contact temperature measurement on most non-reflective non-metal surfaces, such as paper, thick plastics, asphalt, painted surfaces, food, rubber and organic materials, among many others.
- Choice of analogue outputs for measured temperature:
 - Two-wire 4-20 mA,
 - Four-wire 0-50 mV,
 - Four-wire Type K, J or T thermocouple
- Additional sensor body temperature output on four-wire models: indicates the air temperature around the sensor and helps prevent overheating or overcooling



PyroEpsilon with PyroTune emissivity adjuster

The **PyroEpsilon** is a simple infrared temperature sensor with an adjustable emissivity setting. It is ideal if the target is partially reflective.

- Temperature ranges from -20°C to 500°C
- Two-wire 4-20 mA output
- Emissivity adjustment via a separate two-wire 4-20 mA input
- Adjust the emissivity continuously during the process using a variable 4-20 mA source
- Set the emissivity manually with the optional PyroTune emissivity adjuster
- If you are not sure the emissivity of the target is high, choose the PyroEpsilon instead of the PyroCouple



PyroBus sensors with PM180 touch screen display

The **PyroBus** is a networkable, fully configurable infrared temperature sensor with RS485 Modbus RTU communications.

- Temperature ranges from -20°C to 500°C
- Up to 247 sensors may be connected to a single network.
- Adjustable emissivity setting for use on a wide range of materials
- Averaging function to smooth the temperature output
- Peak and valley hold processing for measuring individual objects on a conveyor
- Reflected energy compensation for accurately measuring the temperature of objects in ovens or chillers, from outside
- Optional 6-channel touch screen terminal for local display, configuration and data logging
- Connect sensors and 6-channel terminals directly to an existing RS485 Modbus system



PyroCAN with CAN Bus communications

The **PyroCAN** is an infrared temperature sensor with CAN communications.

- Temperature range: -20°C to 1000°C
- Raw CAN communications
- Adjustable emissivity setting for measuring a variety of materials
- Ideal for onboard vehicle temperature monitoring, and many other applications
- Conforms with EMC standard EN 13309:2010



AE Sensors B.V.
 Postbus 9084, 3301 AB Dordrecht NL
 Tel.: +31 (0)78 6213152
 E-mail : aesensors@aesensors.nl
 Website : www.aesensors.nl

PyroCouple

Two-wire (option 0)

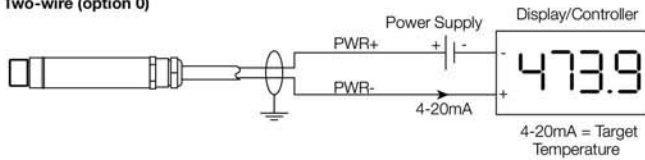

Output types 1 to 4 only (optional)

Four-wire (options 1 to 5)

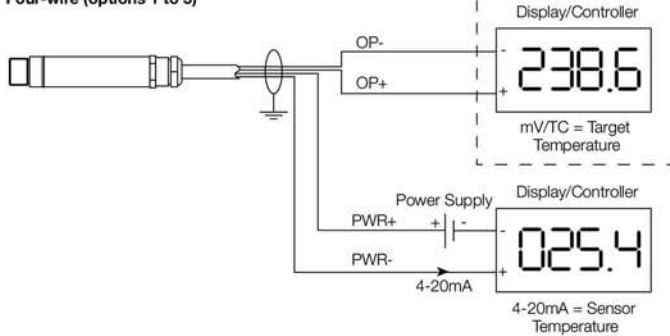

PyroEpsilon

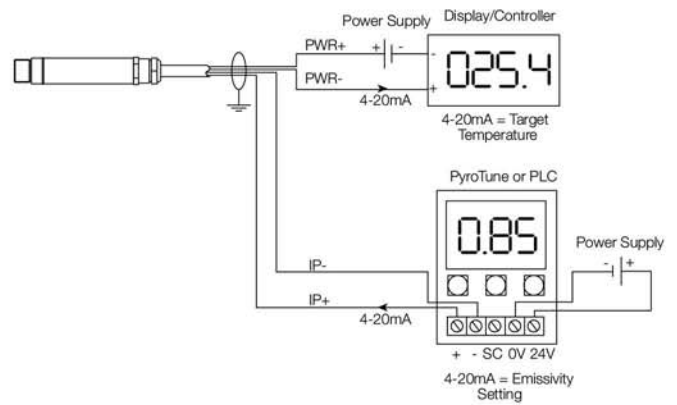

PyroBus

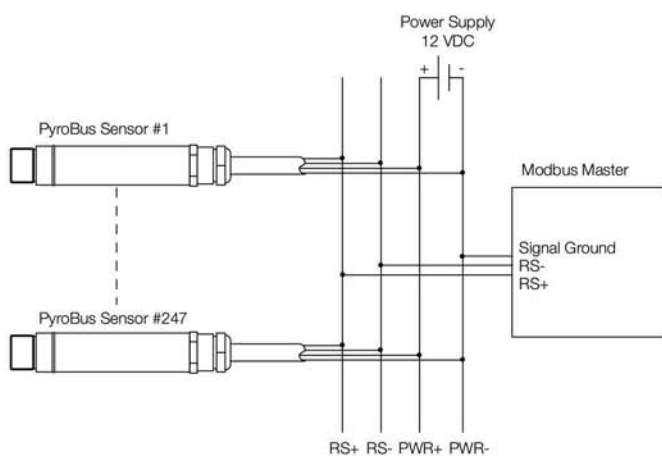

PyroCAN

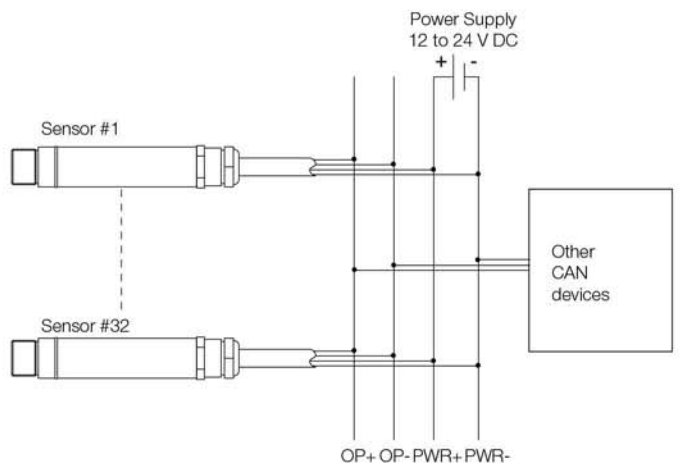

OPTICS

Optics available for PyroCouple, PyroEpsilon, PyroBus

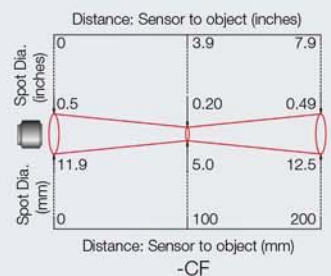
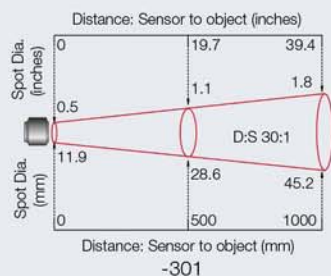
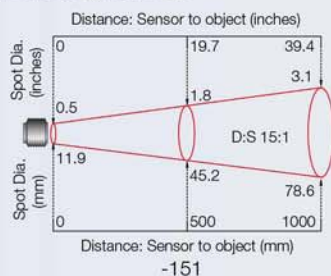
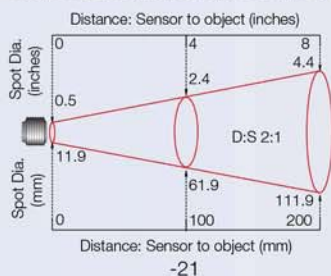

Optics available for PyroCAN

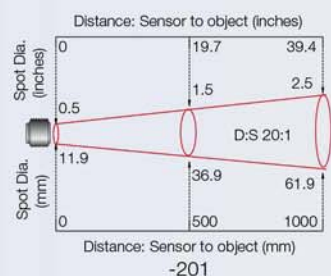
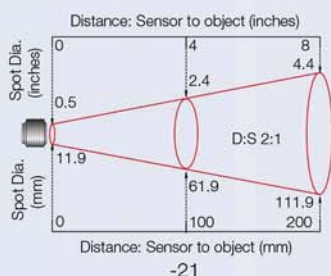

Sensors can measure at longer distances than shown, with a larger measured spot size. Diagrams show the diameter of the measured target spot versus the distance from the sensing head (90% energy).

SPECIFICATIONS



Output (PyroCouple)

PyroCouple Output Option (see Model Numbers)	Target Temperature Output		Sensor Temperature Output	
-0	4-20 mA		Not available	
-1	0-50 mV		4-20 mA	
-3	Type J thermocouple		4-20 mA	
-4	Type K thermocouple		4-20 mA	

	PyroCouple	PyroEpsilon	PyroBus	PyroCAN
Output	See Above	Two-wire 4-20 mA	RS485 Modbus RTU	Raw CAN
Temperature Range	LT = -20 to +100 °C MT = 0 to 250 °C HT = 0 to 500 °C		-20 to 500°C	-20°C to 1000°C
Accuracy	±1% of reading or ±1°C whichever is greater			
Repeatability	± 0.5% of reading or ± 0.5°C whichever is greater			
Emissivity Setting	Fixed at 0.95	Variable 0.2 to 1.0 via continuous 4-20 mA input	Adjustable 0.2 to 1.0 via RS485 Modbus	Adjustable 0.2 to 1.0 via CAN
Response Time	240 ms (90% response)			200 ms (90% response)
Spectral Range	8 to 14 µm			
Supply Voltage	24 V DC (28 V DC max.)		12 V DC (13 V DC max.)	24 V DC (28 V DC max.)
Min. Sensor Voltage	6 V DC			12 V DC
Max. Loop Impedance	900 Ω (4-20 mA output)		-	
Output Impedance	56 Ω (voltage/thermocouple output)	-		
Input Impedance	-		50 Ω	-
Current Draw	20 mA max. (PyroCouple -5 models: 3.2 mA @ 24 V DC)		50 mA max	
Baud Rate	-		9600 bps	250 kbps*
Format	-		8 data bits, no parity, 1 stop bit *	-

* Other configurations available upon request

MECHANICAL

	PyroCouple	PyroEpsilon	PyroBus	PyroCAN
Construction	Stainless Steel			
Dimensions	18 mm diameter x 103 mm long			
Thread Mounting	M16 x 1 mm pitch			
Cable Length	1m (longer lengths available to order)			
Weight with Cable	95 g			

ENVIRONMENTAL

	PyroCouple	PyroEpsilon	PyroBus	PyroCAN
Environmental Rating	IP65			
Ambient (Operating) Temperature Range	0°C to 70°C		0°C to 90°C	
Ambient (Operating) Humidity	95% max. non-condensing			

PYROCAN

Example data message received from sensor:

		Object Temperature				Ambient Temperature			
Bytes	DLC	DATA0	DATA1	DATA2	DATA3	DATA4	DATA5	DATA6	DATA7
Value	8	0x51	0x39	0xB2	0x41	0xA4	0x70	0xDF	0x41
Hex		0x41B23951				0x41DF70A4			
Encoding		Float				Float			
Decimal		22.28 °C				27.93 °C			

PYROTUNE

General Specifications (PyroTune)	
Output	4-20 mA for emissivity adjustment of PyroEpsilon sensor
Supply Voltage	24 V DC (13 V to 28 V DC)
Display Format	3.5 digit LCD
Display Units	Emissivity (0.2 to 1.0) or current (4 - 20 mA)
Adjustment	Push-buttons (raise/lower/set)

Mechanical Specifications (PyroTune)	
Construction	Polycarbonate with gasket, transparent lid (PC) and quick release screws
Mounting	Surface
Dimensions	65 mm tall x 50 mm wide x 35 mm deep
Weight	72 g

Environmental Specifications (PyroTune)	
Environmental Rating	IP65
Ambient Temperature Range	0°C to 70°C
Relative Humidity	95% max. non-condensing

ACCESSORIES



Fixed mounting bracket **FBS**



Air purge collar for 2:1 optics **APSW**
or for all other optics (shown above) **APSN**



Laser sighting tool **LSTS**



Adjustable mounting bracket **ABS**



Air or water cooled jacket with
air purge collar **WJ** (see Model Numbers)



Dual laser sighting bracket, adjustable
DLSBAS or fixed **DLSBFS**



PyroTune emissivity adjuster **PT**
(for PyroEpsilon only)



6-channel touch
screen interface for
temperature display,
configuration and data
logging (PyroBus only)
PM180



Protective plastic window with
stainless steel holder **PWS**
(not compatible with PyroCouple)

MODEL NUMBERS



PyroCouple	PC	151	MT	0	WJ	Example Model Numbers: PC151MT-0, PC301HT-4WJ
PyroEpsilon	PE	151	MT		WJ	Example Model Numbers: PE151MT, PECFHTWJ
PyroBus	PB	151			WJ	Example Model Numbers: PB21, PBCF, PB151WJ
PyroCAN	PCAN	151			WJ	Example Model Numbers: PCAN201, PCAN21WJ

Cooling
(blank) Sensor without cooling
WJ Air/water cooled jacket with air purge collar

Output option (PyroCouple only)
0 2 wire, 4-20mA
1 4-wire, 0-50mV (target temp.), 4-20mA (sensor temp.)
3 4-wire, J Thermocouple (target temp.), 4-20mA (sensor temp.)
4 4-wire, K Thermocouple (target temp.), 4-20mA (sensor temp.)

e.g. Model PC151HT-4 has a type K thermocouple output representing target temperatures of 0°C to 500°C plus a 4-20 mA output proportional to internal sensor temperature. For simplicity, the sensor temperature range is always set the same as the target temperature range

Temperature range (PyroCouple and PyroEpsilon only)
LT -20 to +100 °C
MT 0 to 250 °C
HT 0 to 500 °C

Field of view
21 2:1 divergent optics
151 15:1 divergent optics
201 20:1 general-purpose divergent optics (PCAN series only)
301 30:1 divergent optics
CF Close-focus optics (focal spot size 5 mm at 100mm distance)

Note: PyroCAN sensors are available with 2:1 and 20:1 optics only

Series	Series	Series
PC	PyroCouple	Fixed emissivity, choice of analogue outputs
PE	PyroEpsilon	Adjustable emissivity, 4-20 mA output
PB	PyroBus	Fully configurable, RS485 Modbus communications
PCAN	PyroCAN	Adjustable emissivity, CAN Bus communications



AE Sensors B.V.
Postbus 9084, 3301 AB Dordrecht NL
Tel.: +31 (0)78 6213152
E-mail : aesensors@aesensors.nl
Website : www.aesensors.nl